

Butterfly Flange

SAE 1 1/2" to SAE 5"

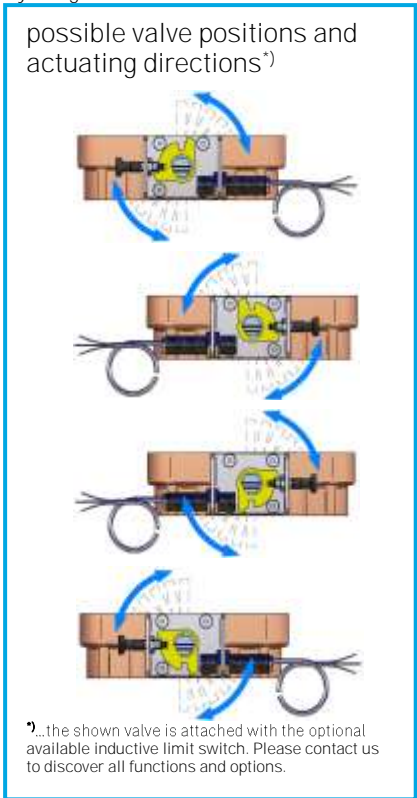

The **asa** butterfly flange with SAE and DIN connections allows the combination with an elastic element (rubber compensator) to make a short compensating and economical connection with the pump port. The lever position can be changed through our new mechanism. The handle direction (clockwise or counter clockwise) can be changed by turning the switch bracket. Please note that the butterfly flange may only be opened in mounted state and with greased or lubricated sealing. The adapter flange may only be welded with demounted butterfly flange.

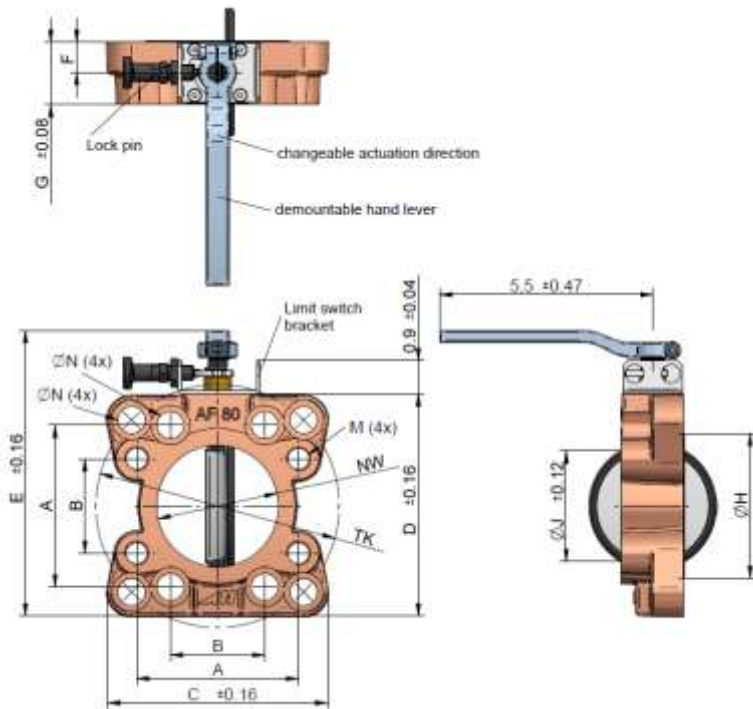

Technical Data

order number	description	size	A	B	C	D	E	F	G	Ø H	J	M	Ø N	NW	TK	weight
		SAE DIN	[in]	[in]	[in]	[in]	[in]	[in]	[in]	[in]	[in]	[in]	[in]	[in]	[in]	[lbs]
SDA0040U00	AF 40	1 1/2" 40	2.76	1.41	4.02	4.72	6.38	0.98	1.69	2.36	0.93	M12	0.53	1.57	4.33	4.78
SDA0050U00	AF 50	2" 50	3.06	1.69	4.37	4.41	6.10	0.79	1.69	2.87	1.41	M12	0.53	1.89	4.92	4.85
SDA0063U00	AF 63	2 1/2" 65	3.50	2.00	4.37	4.69	6.34	0.79	1.57	3.27	2.18	M12	0.53	2.48	4.92	4.74
SDA0080U00	AF 80	3" 80	4.19	2.44	5.67	5.71	7.36	0.79	1.61	3.74	2.91	M16	0.71	3.15	6.30	6.57
SDA0100U00	AF 100	4" 100	5.13	3.06	6.42	6.38	8.07	0.79	1.69	4.84	3.87	M16	0.71	3.94	7.09	8.84
SDA0125U00	AF 125	5" 125	6.00	3.62	7.28	7.28	8.94	0.79	1.69	5.83	4.88	M16	0.71	4.92	8.27	10.58

Working ranges

max. over pressure (open valve)	232 PSI
max. differential pressure (closed valve)	87 PSI
temperature range	-4°F to +176°F

Materials

housing	cast iron
lever	steel
valve disc	aluminum
seals	NBR

Options

limit switch	mechanical or inductive type
FPM sealings	contact us for the Viton valve range
stainless steel	contact us for the stainless steel range
aluminum version	sizes 1 1/2", 2", 2 1/2", 3" on request



This data sheet and the corresponding scale drawings are to be used as a general guideline and technical overview of our products. Please contact us if more exact information is needed. As we are constantly improving our products, their characteristics, dimensions and weights may also change, although we do our best to incorporate these changes continually. asa assumes no liability for any information therein, any errors, omissions, misprints, nor any direct or indirect damages, losses or costs resulting therefrom. Any cooling performances and general technical values indicated in this catalogue are measured at a test bench according to asa testing procedures or calculated, based on such tests. Due to different conditions in testing and application environments the performance may also vary by +/- 15%. Because there is no standardized testing procedure, tests used by other manufacturers could have different results. Therefore we recommend all products to be checked under the system operating conditions. This is also true for vibrations and mechanical stress as well as for pressure peaks and thermal stress and any other relevant factors. General tolerances according to DIN ISO 2768-vL. General tolerances for casted parts according to EN ISO 8062-3 (DCTG 10). Tolerances for rubber parts are according to ISO 3302-1 (class M4-F-C). The tolerances of welding seams are defined by quality group D according to EN ISO 10042, if it is not specified on the actual scale drawing or data sheet. In addition to that we point out that any data sheet and corresponding scale drawing is no substitution for the manual.
 DD-butterfly-valve-us-REV4 © asa technology, February 2021 page 1/1

Butterfly Flange

SAE 1 1/2" to SAE 3" aluminum design



The asa butterfly flange with SAE and DIN connections allows the combination with an elastic element (rubber compensator) to make a short compensating and economical connection with the pump port. The lever position can be changed through our new mechanism. The handle direction (clockwise or counter clockwise) can be changed by turning the switch bracket. Please note that the butterfly flange may only be opened in mounted state and with greased or lubricated sealing. The adapter flange may only be welded with demounted butterfly flange. Please contact us for further information. Please contact us for further information at sales_us@asahydraulik.com or www.asahydraulik.com.

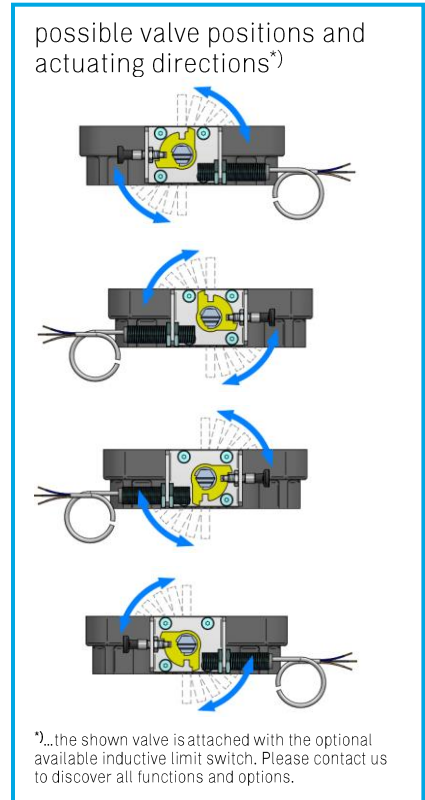
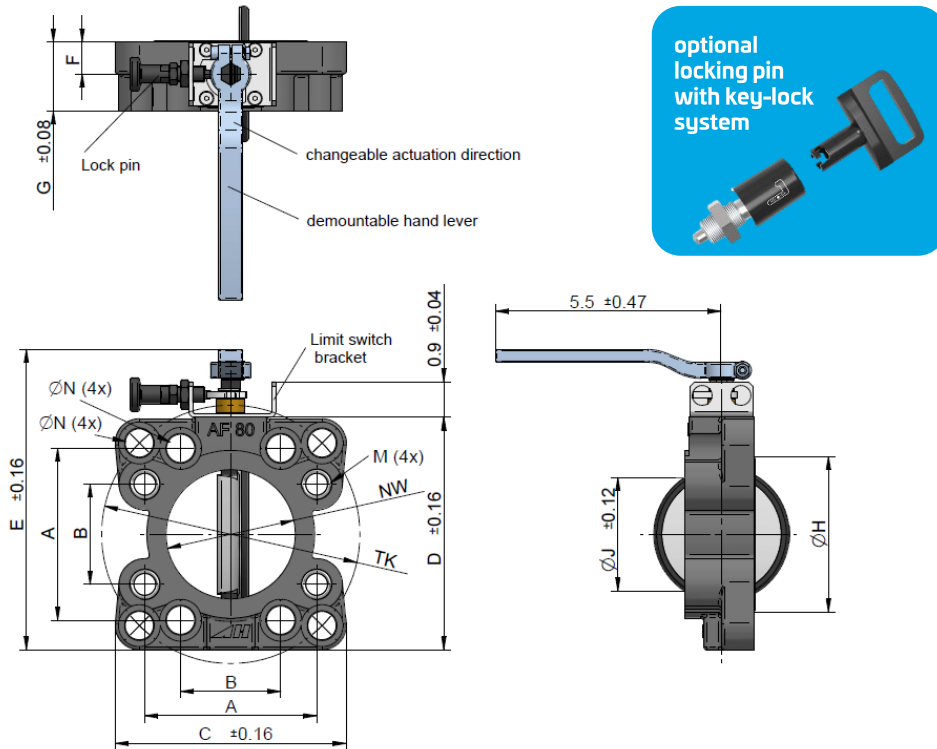

Technical Data

order number	description	size	size	A	B	C	D	E	F	G	Ø H	J	M	Ø N	NW	TK	weight
		SAE	DIN	[in]	[in]	[in]	[in]	[in]	[in]	[in]	[in]	[in]	[in]	[in]	[in]	[in]	[lbs]
SDA0050AU00	AF 50 Alu.	2"	50	3.06	1.69	4.41	4.41	6.10	0.79	1.69	2.87	1.10	M12	0.51	1.89	4.92	2.31
SDA0063AU00	AF 63 Alu.	2 1/2"	65	3.50	2.00	4.37	4.69	6.34	0.79	1.69	3.27	2.01	M12	0.50	2.48	4.92	2.40
SDA0080AU00	AF 80 Alu.	3"	80	4.19	2.44	5.67	5.71	7.36	0.79	1.69	3.74	2.80	M16	0.69	3.15	6.30	3.26

Working ranges

max. over pressure (open valve)	232 PSI
max. differential pressure (closed valve)	87 PSI
temperature range	-4°F to +176°F

Materials

housing	aluminum
lever	steel
valve disc	aluminum
seals	NBR

Options

limit switch	mechanical or inductive type
locking pin	SDARASTBELSSKU00
FPM sealings	contact us for the Viton valve range
spheroidal graphite cast irons version	sizes 1 1/2", 2", 2 1/2", 3", 4", 5" on request
stainless steel	sizes 2", 2 1/2", 3" on request



This data sheet and the corresponding scale drawings are to be used as a general guideline and technical overview of our products. Please contact us if more exact information is needed. As we are constantly improving our products, their characteristics, dimensions and weights may also change, although we do our best to incorporate these changes continually. asa assumes no liability for any information therein, any errors, omissions, misprints, nor any direct or indirect damages, losses or costs resulting therefrom. Any cooling performances and general technical values indicated in this catalogue are measured at a test bench according to asa testing procedures or calculated, based on such tests. They represent a basis for your product selection. Due to different conditions in testing and application environments the performance may also vary by +/- 15%. All sound values are determined in accordance with ISO 9614-2, DIN EN ISO 11203 accuracy class 3 or Machinery Directive 2006/42/EG and are A-rated. At some of the performance data, possible differences to competition data are possible. The reason to that are no existing standardized testing procedures on individual subjects, e.g. for cooling performance measurements. Therefore, we recommend all products to be checked under the system operating conditions. This is also true of vibrations and mechanical stress as well as for pressure peaks and thermal stress and any other relevant factors. General tolerances according to DIN ISO 2768-M, General tolerances for casted parts according to EN ISO 8062-3 (DCTG 10). Tolerances for rubber parts are according to ISO 3302-1 (class M4-F+C). The tolerances of welding seams are defined by quality group D according to EN ISO 10042, if it is not specified on the actual scale drawing or data sheet. Any form of liability is excluded for the information included in this datasheet. All details and calculation values are checked to the best of our ability, but these do not ensure any intrinsic product properties; due to the wide-ranging possible applications, it is advised that all technical data herewith included be confirmed through testing carried out by the end-user. asa technology Produktions- und Vertriebs GmbH reserves the right to modify the product without any separate notification. This refers to both technical data and the product itself. Furthermore, it is herewith specified that the datasheet does not substitute the corresponding scale drawings, assembly and installation guidelines, nor the operating instructions.
DD-butterfly-valves-alu-us-rev5 © asatechnology, April 2023

Butterfly Flange

SAE 1 1/2" to SAE 5" with Viton seals



The **asa** butterfly flange with SAE and DIN connections allows the combination with an elastic element (rubber compensator) to make a short compensating and economical connection with the pump port. The lever position can be changed through our new mechanism. The handle direction (clockwise or counter clockwise) can be changed by turning the switch bracket. Please note that the butterfly flange may only be opened in mounted state and with greased or lubricated sealing. The adapter flange may only be welded with demounted butterfly flange.

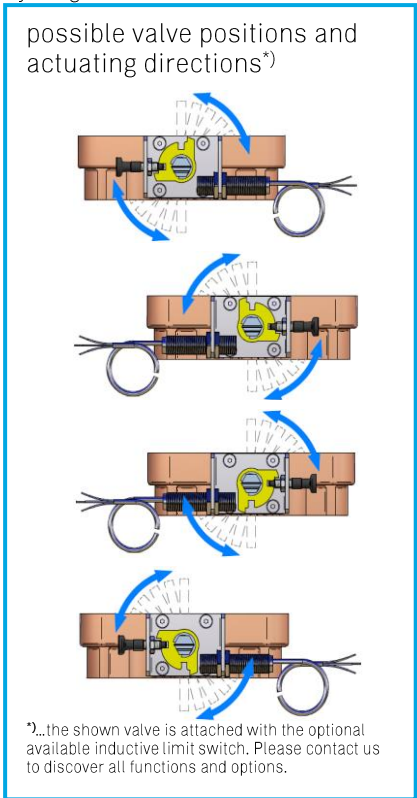
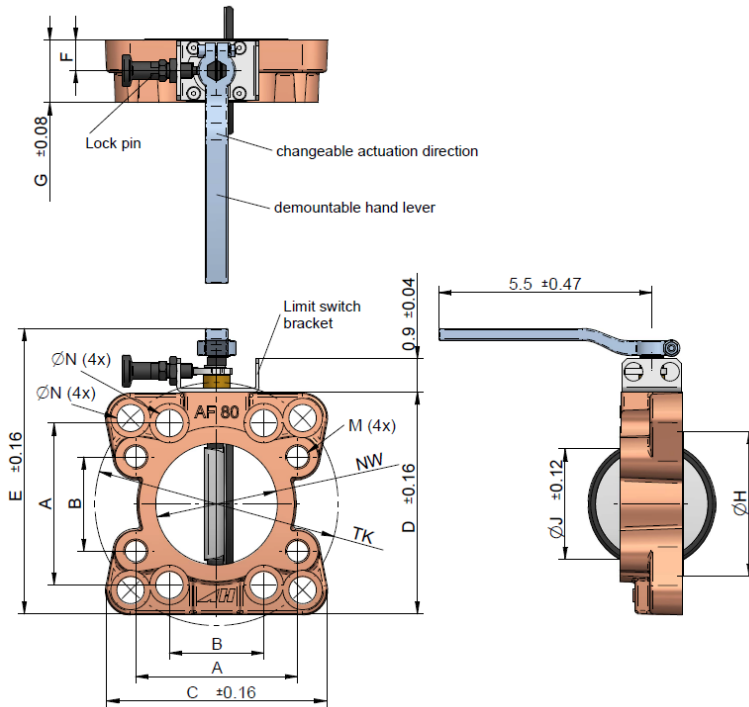

Technical Data

order number	description	size	A	B	C	D	E	F	G	Ø H	J	M	Ø N	NW	TK	weight
		SAE DIN	[in]	[in]	[in]	[in]	[in]	[in]	[in]	[in]	[in]	[in]	[in]	[in]	[in]	[lbs]
SDA0040VU00	AF 40 Viton	1 1/2" 40	2.76	1.41	4.02	4.72	6.38	0.98	1.69	2.36	0.93	M12	0.53	1.57	4.33	4.78
SDA0050VU00	AF 50 Viton	2" 50	3.06	1.69	4.37	4.41	6.10	0.79	1.69	2.87	1.41	M12	0.53	1.89	4.92	4.85
SDA0063VU00	AF 63 Viton	2 1/2" 65	3.50	2.00	4.37	4.69	6.34	0.79	1.57	3.27	2.18	M12	0.53	2.48	4.92	4.74
SDA0080VU00	AF 80 Viton	3" 80	4.19	2.44	5.67	5.71	7.36	0.79	1.61	3.74	2.91	M16	0.71	3.15	6.30	6.57
SDA0100VU00	AF 100 Viton	4" 100	5.13	3.06	6.42	6.38	8.07	0.79	1.69	4.84	3.87	M16	0.71	3.94	7.09	8.84
SDA0125VU00	AF 125 Viton	5" 125	6.00	3.62	7.28	7.28	8.94	0.79	1.69	5.83	4.88	M16	0.71	4.92	8.27	10.58

Working ranges

max. over pressure (open valve)	232 PSI
max. differential pressure (closed valve)	87 PSI
temperature range	-4°F to +302°F

Materials

housing	cast iron
lever	steel
valve disc	aluminum
seals	viton (FPM)

Options

limit switch	mechanical or inductive type
cast iron valve housing	all sizes available
stainless steel valve housing	sizes 2", 2 1/2", 3" on request
aluminium valve housing	sizes 2", 2 1/2", 3" on request

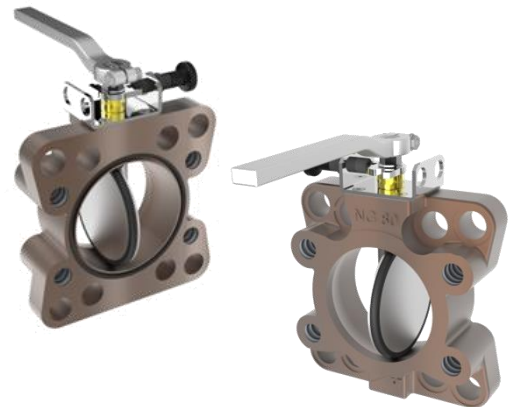

This data sheet and the corresponding scale drawings are to be used as a general guideline and technical overview of our products. Please contact us if more exact information is needed. As we are constantly improving our products, their characteristics, dimensions and weights may also change, although we do our best to incorporate these changes continually. asa assumes no liability for any information therein, any errors, omissions, misprints, nor any direct or indirect damages, losses or costs resulting therefrom. Any cooling performances and general technical values indicated in this catalogue are measured at a test bench according to asa testing procedures or calculated, based on such tests. Due to different conditions in testing and application environments the performance may also vary by +/- 15%. Because there is no standardized testing procedure, tests used by other manufacturers could have different results. Therefore we recommend all products to be checked under the system operating conditions. This is also true for vibrations and mechanical stress as well as for pressure peaks and thermal stress and any other relevant factors. General tolerances according to DIN ISO 2768-vL. General tolerances for casted parts according EN ISO 8062-3 (DCTG 10). Tolerances for rubber parts are according to ISO 3302-1 (class M4-F+C). The tolerances of welding seams are defined by quality group D according to EN ISO 10042, if it is not specified on the actual scale drawing or data sheet. In addition to that we point out that any data sheet and corresponding scale drawing is no substitution for the manual.
 DD-butterfly-valve-Viton-us-rev0 © asa technology, October 2021 page1/1