

# ASA Series Oil / Air Cooler

## 12V / 24V DC

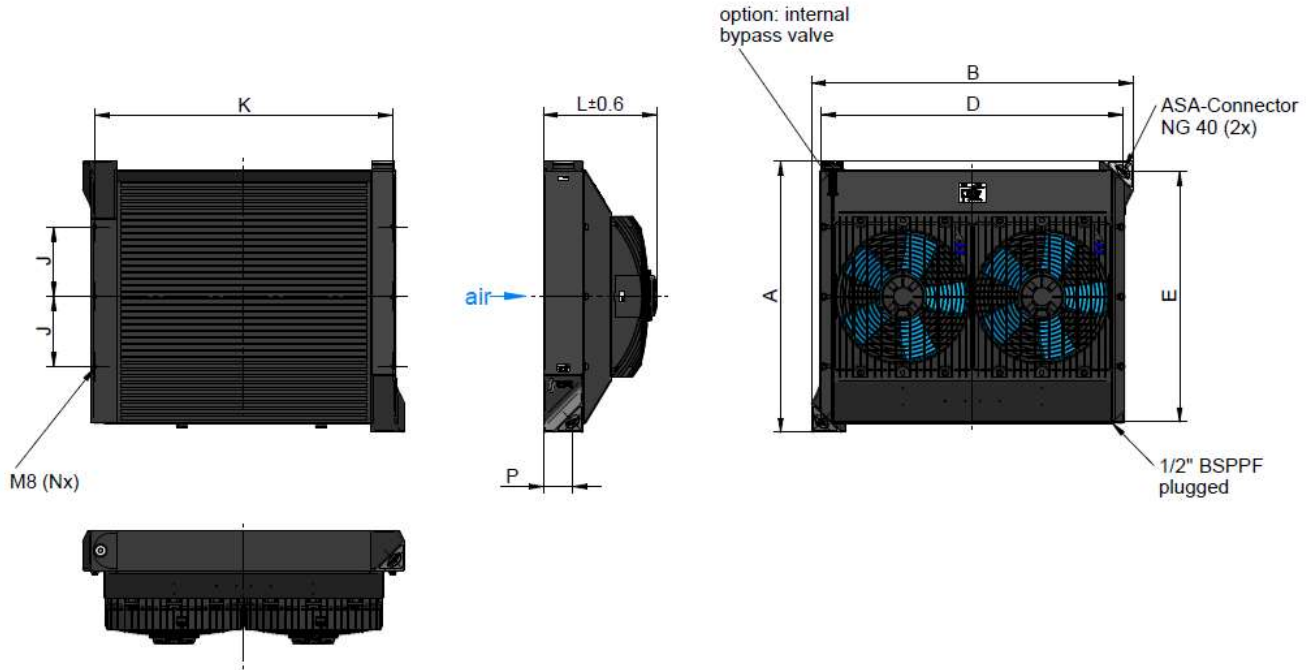

### Dimensions

order number	description	A	B	D	J	K	L	N	P	weight
		[in]	[in]	[in]	[in]	[in]	[in]		[in]	[lbs]
ASA0177AD01U00	ASA 0177 12V DC	18.35	22.91	21.06	6.02	20.47	8.98	4	2.68	54.01
ASA0177AD02U00	ASA 0177 24V DC	18.35	22.91	21.06	6.02	20.47	8.98	4	2.68	54.01
ASA0257AD03U00	ASA 0257 12V DC h.p.	21.85	27.17	25.00	8.21	24.41	10.20	6	2.68	79.81
ASA0257AD04U00	ASA 0257 24V DC h.p.	21.85	27.17	25.00	8.21	24.41	10.20	6	2.68	79.81
ASA0367AD01U00	ASA 0367 12V DC	25.28	30.00	28.11	6.50	27.72	10.55	6	2.68	91.93
ASA0367AD02U00	ASA 0367 24V DC	25.28	30.00	28.11	6.50	27.72	10.55	6	2.68	91.93

### Technical Data

order number	description	motor power	current	protection level	air flow	noise level	optional internal bypass (30PSI)
		[HP]	[A]		[CFM]	[db(A)]	cooler order number
ASA0177AD01U00	ASA 0177 12V DC	0.28*	21.2*	IP 68	1110	79	ASA0177AD01BPU00
ASA0177AD02U00	ASA 0177 24V DC	0.40*	11.4*	IP 68	1110	79	ASA0177AD02BPU00
ASA0257AD03U00	ASA 0257 12V DC	2x0.39	2x22.6	IP 68	2148	83	ASA0257AD03BPU00
ASA0257AD04U00	ASA 0257 24V DC	2x0.40	2x11.4	IP 68	2148	83	ASA0257AD04BPU00
ASA0367AD01U00	ASA 0367 12V DC	2x0.39	2x22.6	IP 68	2059	84	ASA0367AD01BPU00
ASA0367AD02U00	ASA 0367 24V DC	2x0.40	2x11.4	IP 68	2059	84	ASA0367AD02BPU00

\*...single fan

# ASA Series Oil / Air Cooler

## 12V / 24V DC



### Performance

specific cooling performance

all products  
water/glycol  
compatibel

Contact us!

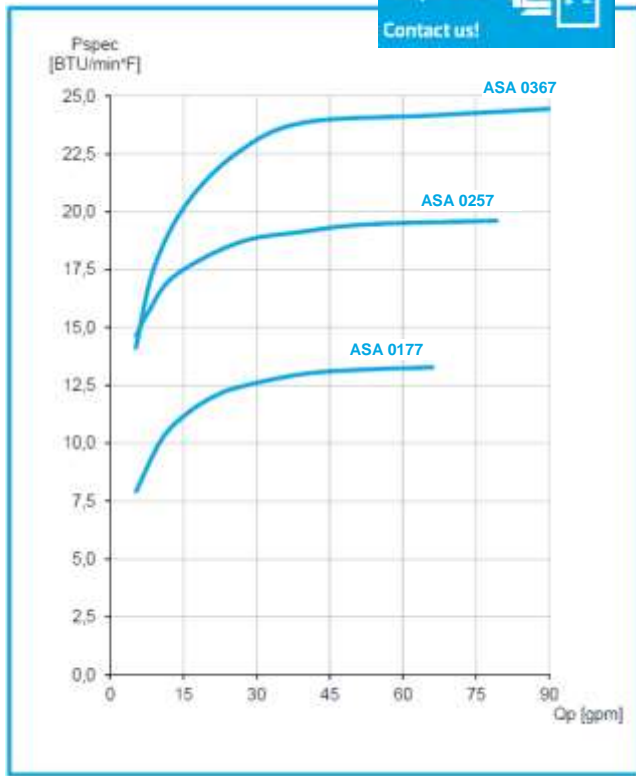

pressure drop at 150 SSU

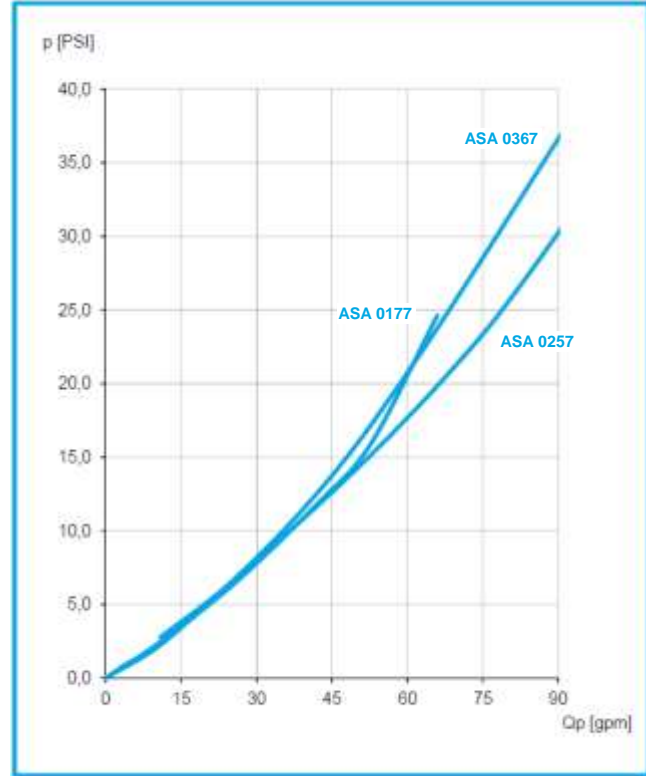

### Radiator Style C

material:	aluminum
working temperature range:	-4°F to +176°F (oil temperature)*
air fin shape:	wavy
working pressure:	370 PSI (static)

\*...the indicated temperature is the maximum inlet temperature for the cooler radiator. Depending on the sealings in use, the application needs appropriate checking.

### Options

temperature control	ILLZTC12-2KU00or 24-2KU00 + ILLZTT5069KU00 (page 30,34)
temperature switches	ILLZTH5069KU00, ILLZTH4765KU00, ILLZTH6065KU00 (page 35)
Intermediate plate NG40	ILLZASA40-40G12U00 (page 29)
internal bypass	alternative bypass settings (7 PSI / 50 PSI)

### Installation System (see more information on page 29)

connection UN 1 5/8"	ILLZASA32U32 (2 pieces per cooler required)
connection UN 1 7/8"	ILLZASA40U24 (2 pieces per cooler required)

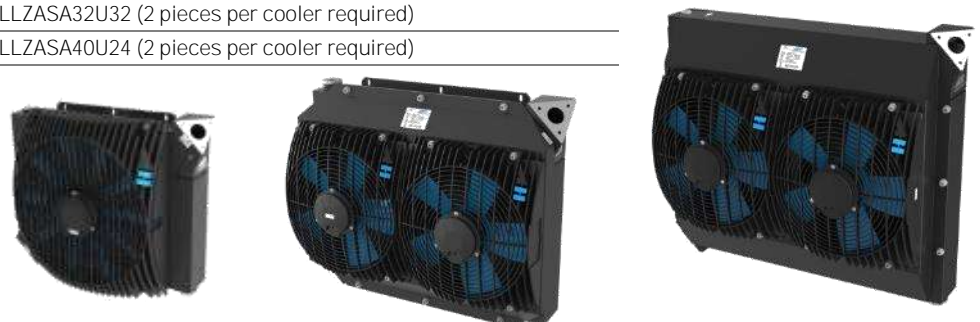

This data sheet and the corresponding scale drawings are to be used as a general guideline and technical overview of our products. Please contact us if more exact information is needed. As we are constantly improving our products, their characteristics, dimensions and weights may also change, although we do our best to incorporate these changes continually. asa assumes no liability for any information therein, any errors, omissions, misprints, nor any direct or indirect damages, losses or costs resulting therefrom. Any cooling performances and general technical values indicated in this catalogue are measured at a test bench according to asa testing procedures or calculated, based on such tests. Due to different conditions in testing and application environments the performance may also vary by +/- 15%. Because there is no standardized testing procedure, tests used by other manufacturers could have different results. Therefore we recommend all products to be checked under the system operating conditions. This is also true for vibrations and mechanical stress as well as for pressure peaks and thermal stress and any other relevant factors. General tolerances according to DIN ISO 2768-vL. General tolerances for casted parts according EN ISO 8062-3 (DCTG 10). Tolerances for rubber parts are according to ISO 3302-1 (class M4-F+C). The tolerances of welding seams are defined by quality group D according to EN ISO 10042, if it is not specified on the actual scale drawing or data sheet. In addition to that we point out that any data sheet and corresponding scale drawing is no substitution for the manual.

# ASA Series Oil / Air Cooler

## 230/460 60Hz AC

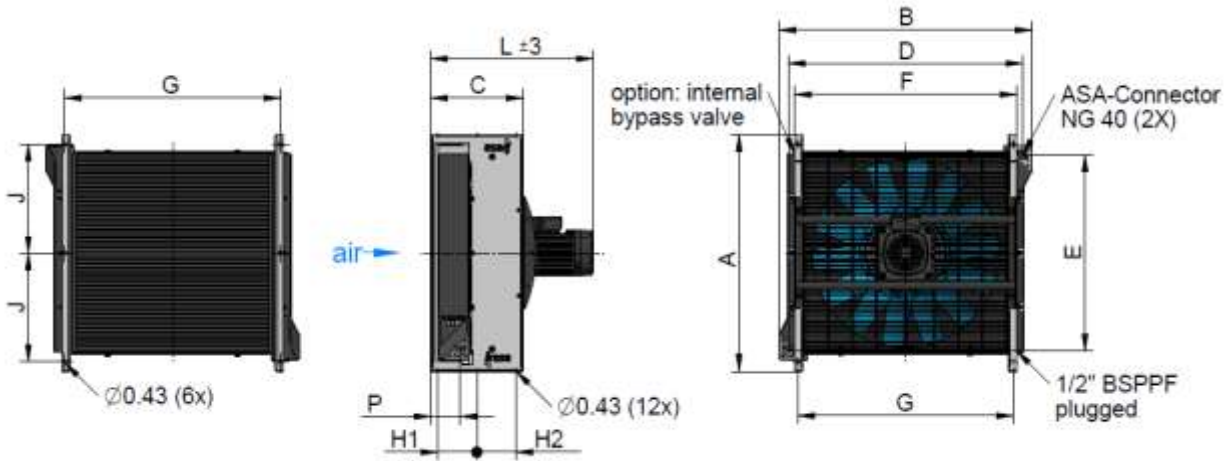

### Dimensions

order number	description	A	B	C	D	E	F	G	H1	H2	J	L	P	weight
		[in]	[in]	[in]	[in]	[in]	[in]	[in]	[in]	[in]	[in]	[in]	[in]	[lbs]
ASA0177AA64U00	ASA 0177 0.25HP AC	20.87	22.91	10.24	21.02	16.38	18.19	17.40	4.72	3.54	19.29	19.1	3.50	86.60
ASA0177AA45U00	ASA 0177 0.50HP AC	20.87	22.91	10.24	21.02	16.38	18.19	17.40	4.72	3.54	19.29	19.1	3.50	85.30
ASA0257AA66U00	ASA 0257 0.50HP AC	25.00	26.85	10.63	24.96	19.72	22.13	21.34	4.33	4.33	11.02	20.5	3.66	107.14
ASA0257AA46U00	ASA 0257 0.75HP AC	25.00	26.85	10.63	24.96	19.72	22.13	21.34	4.33	4.33	11.02	20.5	3.66	106.48
ASA0257AA47U00	ASA 0257 1.02HPAC	25.00	26.85	10.63	24.96	19.72	22.13	21.34	4.33	4.33	11.02	20.5	3.66	106.48
ASA0367AA66U00	ASA 0367 0.50HP AC	28.35	30.00	11.02	28.15	23.46	26.61	25.83	4.72	4.72	12.99	21	3.62	138.60
ASA0367AA46U00	ASA 0367 0.75HP AC	28.35	30.00	11.02	28.15	23.46	26.61	25.83	4.72	4.72	12.99	21	3.62	130.90
ASA0367AA48U00	ASA 0367 1.50HP AC	30.91	30.00	11.02	28.15	23.46	26.61	25.83	4.72	4.72	12.99	21	3.62	141.02
ASA0467AA66U00	ASA 0467 0.50HP AC	30.91	32.95	11.42	31.06	26.30	29.84	29.06	4.92	4.92	14.76	21.7	3.70	175.78
ASA0467AA48U00	ASA 0467 1.50HP AC	30.91	32.95	11.42	31.06	26.30	29.84	29.06	4.92	4.92	14.76	21.7	3.70	189.70
ASA0467AA4BU00	ASA 0467 4.00HP AC	30.91	32.95	11.42	31.06	26.30	29.84	29.06	4.92	4.92	14.76	25	3.70	236.30
ASA0567AA66U00	ASA 0567 0.50HP AC	33.86	36.22	11.42	34.06	29.37	32.52	31.73	4.92	4.92	15.75	21.4	3.62	174.90
ASA0567AA48U00	ASA 0567 1.50HP AC	33.86	36.22	11.42	34.06	29.37	32.52	31.73	4.92	4.92	15.75	21.4	3.62	177.32
ASA0567AA4BU00	ASA 0567 4.00HP AC	33.86	36.22	11.42	34.06	29.37	32.52	31.73	4.92	4.92	15.75	24.7	3.62	203.06
ASA0727AA6AU00	ASA 0727 3.00HP AC	37.80	39.84	14.17	37.95	33.54	36.85	35.91	6.30	6.30	18.11	25.2	3.74	296.12
ASA0727AA4BU00	ASA 0727 4.00HP AC	37.80	39.84	14.17	37.95	33.54	36.85	35.91	6.30	6.30	18.11	25.2	3.74	289.30
ASA0927AA6CU00	ASA 0927 3.00HP AC	43.31	46.06	12.60	43.90	35.91	41.65	40.59	5.12	5.12	20.57	26.1	3.43	309.10
ASA0927AA6EU00	ASA 0927 5.50HP AC	43.31	46.06	12.60	43.90	35.91	41.65	40.59	5.12	5.12	20.57	28.6	3.43	392.92

### Technical Data

order number	description	motor power	current	protection level	rotation	air flow	noise level	optional internal bypass (30PSI)
		[HP]	[A]		[rpm]	[CFM]	[db(A)]	cooler order number
ASA0177AA64U00	ASA 0177 0.25HP AC	0.25	0.6	IP 55	1120	1164	71	ASA0177AA64BPU00
ASA0177AA45U00	ASA 0177 0.50HP AC	0.50	1.0	IP 55	1655	1760	79	ASA0177AA45BPU00
ASA0257AA66U00	ASA 0257 0.50HP AC	0.50	1.1	IP 55	1105	1896	72	ASA0257AA66BPU00
ASA0257AA46U00	ASA 0257 0.75HP AC	0.75	1.4	IP 55	1680	2976	81	ASA0257AA46BPU00
ASA0367AA66U00	ASA 0367 0.50HP AC	0.50	1.1	IP 55	1105	2866	80	ASA0367AA66BPU00
ASA0367AA46U00	ASA 0367 0.75HP AC	0.75	1.4	IP 55	1680	3537	88	ASA0367AA46BPU00
ASA0367AA48U00	ASA 0367 1.50HP AC	1.50	2.1	IP 55	1720	4544	89	ASA0367AA48BPU00
ASA0467AA66U00	ASA 0467 0.50HP AC	0.50	1.1	IP 55	1105	3294	80	ASA0467AA66BPU00
ASA0467AA48U00	ASA 0467 1.50HP AC	1.50	2.1	IP 55	1720	5441	90	ASA0467AA48BPU00
ASA0467AA4BU00	ASA 0467 4.00HP AC	4.00	5.5	IP 55	1730	7972	93	ASA0467AA4BBPU00
ASA0567AA66U00	ASA 0567 0.50HP AC	0.50	1.1	IP 55	1105	3559	80	ASA0567AA66BPU00
ASA0567AA48U00	ASA 0567 1.50HP AC	1.50	2.1	IP 55	1720	5937	90	ASA0567AA48BPU00
ASA0567AA4BU00	ASA 0567 4.00HP AC	4.00	5.5	IP 55	1730	9093	93	ASA0567AA4BBPU00
ASA0727AA6AU00	ASA 0727 3.00HP AC	3.00	3.80	IP 55	1130	9241	84	ASA0727AA6ABPU00
ASA0727AA4BU00	ASA 0727 4.00HP AC	4.00	5.50	IP 55	1730	10968	97	ASA0727AA4BBPU00
ASA0927AA6CU00	ASA 0927 3.00HP AC	3.00	3.8	IP 55	1130	11971	93	on request
ASA0927AA6EU00	ASA 0927 5.50HP AC	5.50	6.60	IP 55	1175	15032	93	on request

This data sheet and the corresponding scale drawings are to be used as a general guideline and technical overview of our products. Please contact us if more exact information is needed. As we are constantly improving our products, their characteristics, dimensions and weights may also change, although we do our best to incorporate these changes continually. asa assumes no liability for any information therein, any errors, omissions, misprints, nor any direct or indirect damages, losses or costs resulting therefrom. Any cooling performances and general technical values indicated in this catalogue are measured at a test bench according to a testing procedure or calculated, based on such tests. Due to different conditions in testing and application environments the performance may also vary by +/- 15%. Because there is no standardized testing procedure, tests used by other manufacturers could have different results. Therefore we recommend all products to be checked under the system operating conditions. This is also true for vibrations and mechanical stress as well as for pressure peaks and thermal stress and any other relevant factors. General tolerances according to DIN ISO 2768-vL. General tolerances for casted parts according EN ISO 8062-3 (DCTG 10). Tolerances for rubber parts are according to ISO 3302-1 (class M4-F+C). The tolerances of welding seams are defined by quality group D according to EN ISO 10042, if it is not specified on the actual scale drawing or data sheet. In addition to that we point out that any data sheet and corresponding scale drawing is no substitution for the manual.

# ASA Series Oil / Air Cooler

## 230/460 60Hz AC



### Performance

specific cooling performance

all products  
water/glycol  
compatible  
Contact us!

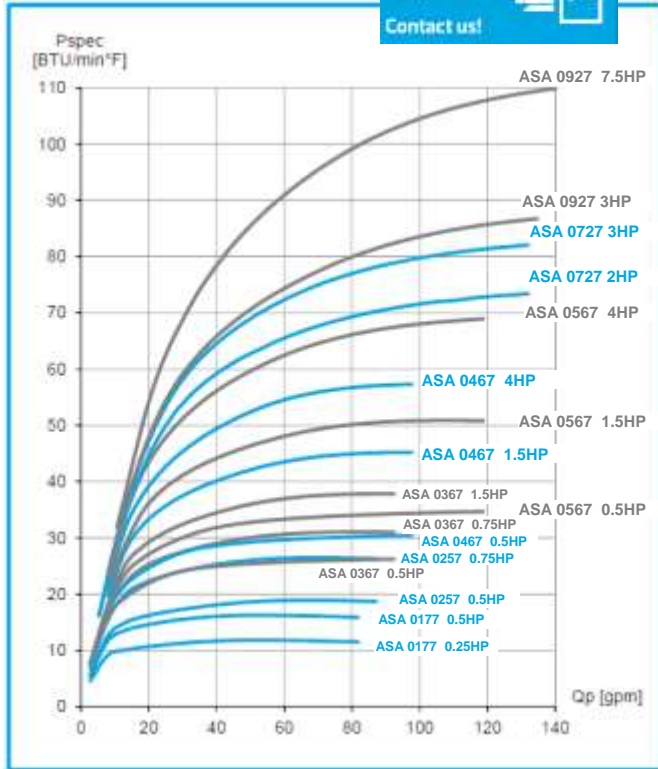

pressure drop at 150 SSU

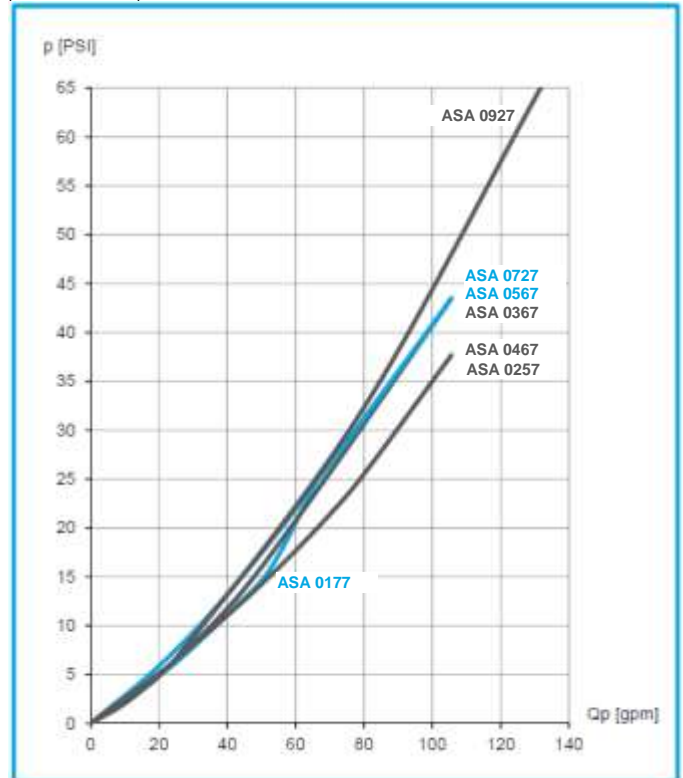

### Radiator Style C

material:	aluminum
working temperature range:	-4°F to +176°F (oil temperature)*
air fin shape:	wavy
working pressure:	370 PSI (static)

\*...the indicated temperature is the maximum inlet temperature for the cooler radiator. Depending on the sealings in use, the application needs appropriate checking.

### Options

motor data	alternative voltages, frequencies, IP classes, etc on request
temperature switch	ILLZTH4765KU00, ILLZTH6065KU00 (page 35)
tread plate & radiator guard	see page 31
internal bypass	alternative bypass settings (7 PSI / 50 PSI)
Intermediate plate NG40	ILLZASA40-40G12 (page 29)

### Installation System (see more information on page 29)

connection NG 32-UN 1 5/8"	ILLZASA32U20 (2 pieces per cooler required)
connection NG 40-UN 1 7/8"	ILLZASA40U24 (2 pieces per cooler required)

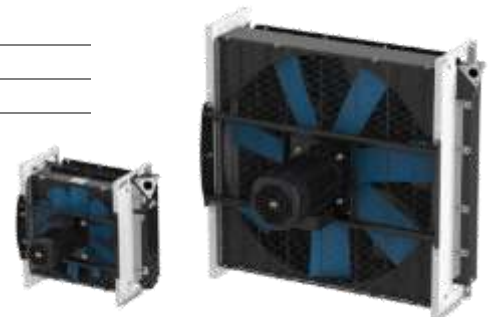

This data sheet and the corresponding scale drawings are to be used as a general guideline and technical overview of our products. Please contact us if more exact information is needed. As we are constantly improving our products, their characteristics, dimensions and weights may also change, although we do our best to incorporate these changes continually. asa assumes no liability for any information therein, any errors, omissions, misprints, nor any direct or indirect damages, losses or costs resulting therefrom. Any cooling performances and general technical values indicated in this catalogue are measured at a test bench according to a test procedure or calculated, based on such tests. Due to different conditions in testing and application environments the performance may also vary by +/- 15%. Because there is no standardized testing procedure, tests used by other manufacturers could have different results. Therefore we recommend all products to be checked under the system operating conditions. This is also true for vibrations and mechanical stress as well as for pressure peaks and thermal stress and any other relevant factors. General tolerances according to DIN ISO 2768-vL. General tolerances for casted parts according EN ISO 8062-3 (DCTG 10). Tolerances for rubber parts are according to ISO 3302-1 (class M4-F+C). The tolerances of welding seams are defined by quality group D according to EN ISO 10042, if it is not specified on the actual scale drawing or data sheet. In addition to that we point out that any data sheet and corresponding scale drawing is no substitution for the manual.

# ASA Series Oil / Air Cooler

with 0.73in<sup>3</sup> and 0.67 in<sup>3</sup> hydraulic drive

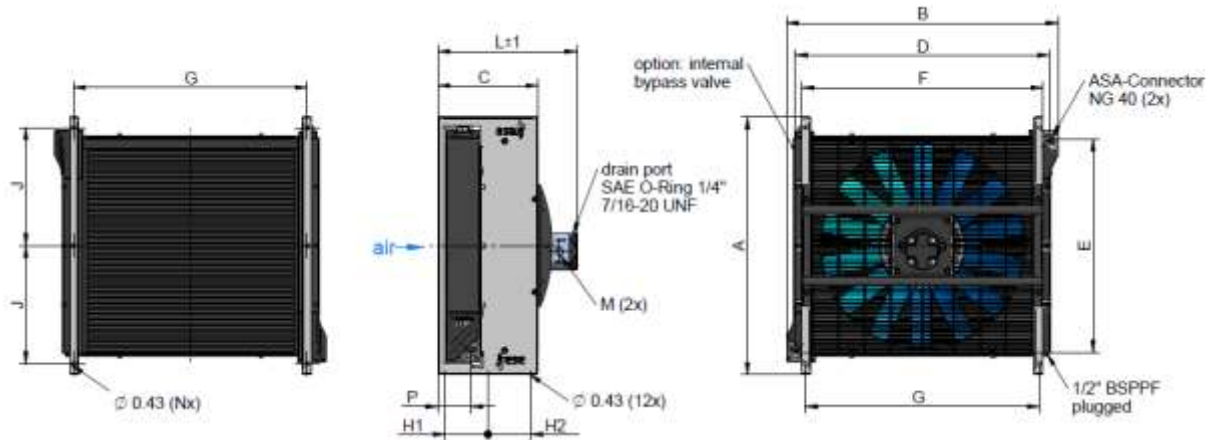

## Dimensions

order number	description	A	B	C	D	E	F	G	H1	H2	J	L	P	weight
		[in]	[in]	[in]	[in]	[in]	[in]	[in]	[in]	[in]	[in]	[in]	[in]	[lbs]
ASA0177AH12U00	ASA 0177 hydr. motor 0.73in <sup>3</sup>	20.87	22.91	10.24	21.02	16.38	18.19	17.40	4.72	3.54	19.29	14.33	3.50	78.9
ASA0257AH12U00	ASA 0257 hydr. motor 0.73in <sup>3</sup>	25.00	26.85	10.63	24.96	19.72	22.13	21.34	4.33	4.33	11.02	15.08	3.66	98.1
ASA0367AH11U00	ASA 0367 hydr. motor 0.67in <sup>3</sup>	28.35	30.39	11.02	28.15	23.46	26.61	25.83	4.72	4.72	12.99	16.93	3.62	124.3
ASA0467AH11U00	ASA 0467 hydr. motor 0.67in <sup>3</sup>	31.91	32.95	11.42	31.06	26.30	29.84	29.06	4.92	4.92	14.76	17.64	3.70	160.7
ASA0567AH11U00	ASA 0567 hydr. motor 0.67in <sup>3</sup>	33.86	36.22	11.42	34.06	29.37	32.52	31.73	4.92	4.92	15.75	17.64	3.62	163.4
ASA0727AH11U00	ASA 0727 hydr. motor 0.67in <sup>3</sup>	37.80	39.84	14.17	37.95	33.54	36.85	35.91	6.30	6.30	18.11	20.51	3.74	227.1
ASA0927AH11U00	ASA 0927 hydr. motor 0.67in <sup>3</sup>	43.31	46.06	12.60	43.09	35.91	41.65	40.59	5.12	5.12	19.86	18.70	3.43	275.6

## Technical Data

order number	description	motor power	oil pressure	oil flow	rotation	air flow	noise level	optional internal bypass (30PSI)
		[HP]	[PSI]	[gpm]	[rpm]	[CFM]	[db(A)]	cooler order number
ASA0177AH12U00	ASA 0177 hydr. motor 0.73in <sup>3</sup>	0.08	46	3,3	1000	1038	69	ASA0177AH11BPU00
		0.60	172	6,7	2000	2161	84	
		2.00	382	10,0	3000	3323	92	
ASA0257AH12U00	ASA 0257 hydr. motor 0.73in <sup>3</sup>	0.14	80	3,3	1000	1713	70	ASA0257AH12BPU00
		1.11	318	6,7	2000	3590	85	
		3.70	707	10,0	3000	5510	94	
ASA0367AH11U00	ASA 0367 hydr. motor 0.67in <sup>3</sup>	0.60	375	3,1	1000	3522	74	ASA0367AH11BPU00
		2.06	857	4,6	1500	5545	83	
		4.91	1532	6,1	2000	7428	89	
ASA0467AH11U00	ASA 0467 hydr. motor 0.67in <sup>3</sup>	0.28	175	3,1	1000	2955	78	ASA0467AH11BPU00
		1.14	445	4,9	1600	4866	88	
		2.97	843	6,7	2200	6803	95	
ASA0567AH11U00	ASA 0567 hydr. motor 0.67in <sup>3</sup>	0.27	169	3,1	1000	3200	78	ASA0567AH11BPU00
		1.10	429	4,9	1600	5260	88	
		2.86	811	6,7	2200	7308	95	
ASA0727AH11U00	ASA 0727 hydr. motor 0.67in <sup>3</sup>	0.65	406	3,1	1000	6120	85	ASA0727AH11BPU00
		1.80	803	4,3	1400	8746	93	
		3.81	1321	5,5	1800	11430	98	
ASA0927AH11U00	ASA 0927 hydr. motor 0.67in <sup>3</sup>	2.05	1280	3,1	1000	10483	90	on request
		4.50	2161	4,0	1300	13967	96	
		8.34	3254	4,9	1600	17534	100	

This data sheet and the corresponding scale drawings are to be used as a general guideline and technical overview of our products. Please contact us if more exact information is needed. As we are constantly improving our products, their characteristics, dimensions and weights may also change, although we do our best to incorporate these changes continually. asa assumes no liability for any information therein, any errors, omissions, misprints, nor any direct or indirect damages, losses or costs resulting therefrom. Any cooling performances and general technical values indicated in this catalogue are measured at a test bench according to asa testing procedures or calculated, based on such tests. Due to different conditions in testing and application environments the performance may also vary by +/- 15%. Because there is no standardized testing procedure, tests used by other manufacturers could have different results. Therefore we recommend all products to be checked under the system operating conditions. This is also true for vibrations and mechanical stress as well as for pressure peaks and thermal stress and any other relevant factors. General tolerances according to DIN ISO 2768-vL. General tolerances for casted parts according to EN ISO 8062-3 (DCTG 10). Tolerances for rubber parts are according to ISO 3302-1 (class M4-F+C). The tolerances of welding seams are defined by quality group D according to EN ISO 10042, if it is not specified on the actual scale drawing or data sheet. In addition to that we point out that any data sheet and corresponding scale drawing is no substitution for the manual.

# ASA Series Oil / Air Cooler with 0.73in<sup>3</sup> and 0.67 in<sup>3</sup> hydraulic drive



## Performance

specific cooling performance

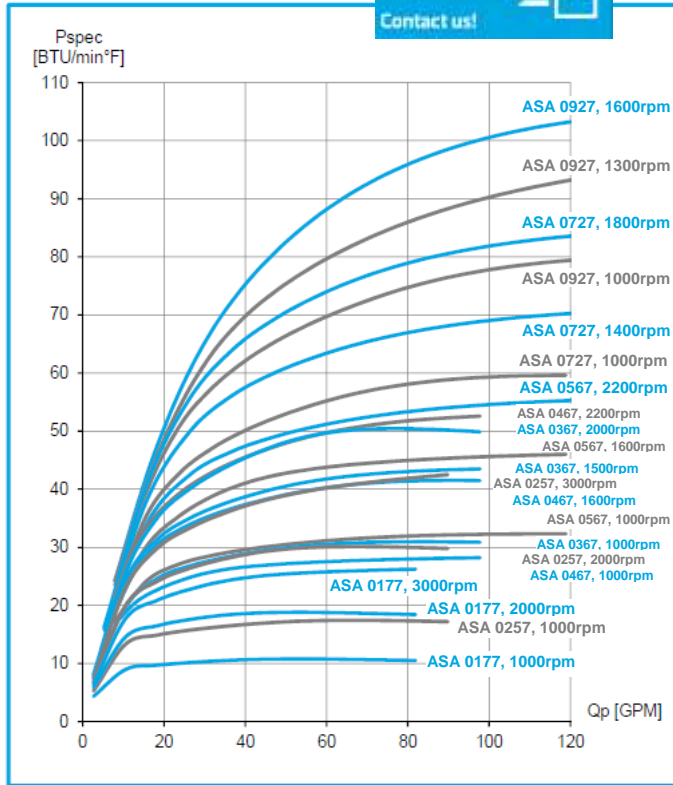

pressure drop at 150 SSU

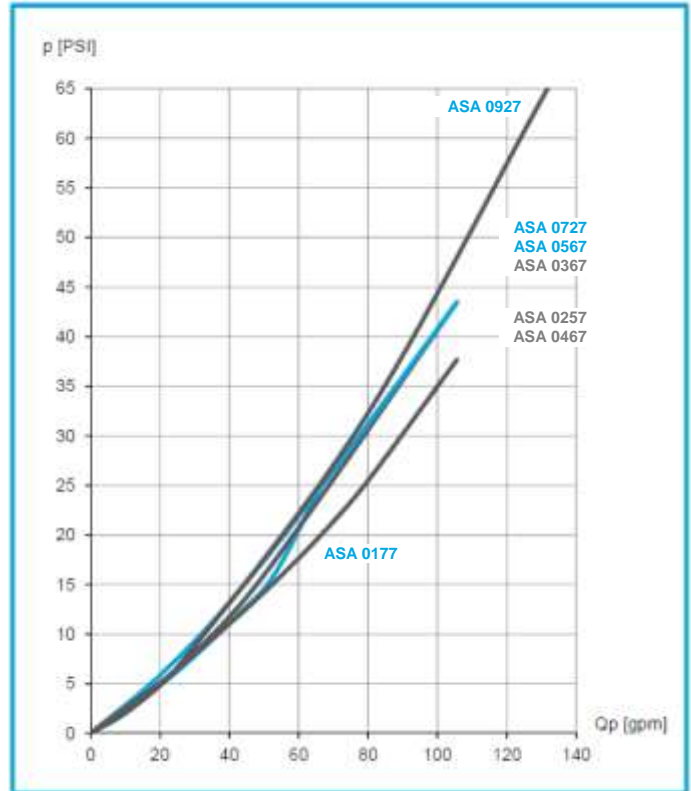

## Radiator Style C

material:	aluminum
working temperature range:	-4°F to +176°F (oil temperature)*
air fin shape:	wavy
working pressure:	370 PSI (static)

\*...the indicated temperature is the maximum inlet temperature for the cooler radiator. Depending on the sealings in use, the application needs appropriate checking.

## Options

hydraulic motor	alternative displacements on request
temperature switch	ILLZTH4765KU00, ILLZTH6065KU00 (page 35)
tread plate & radiator guard	see page 31
internal bypass	alternative bypass settings (7 PSI / 50 PSI)
Intermediate plate NG 40	ILLZASA40-40G12U00 (page 29)

## Installation System (see more information on page 29)

connection UN 1 5/8"	ILLZASA32U20U00 (2 pieces per cooler required)
connection UN 1 7/8"	ILLZASA40U24U00 (2 pieces per cooler required)

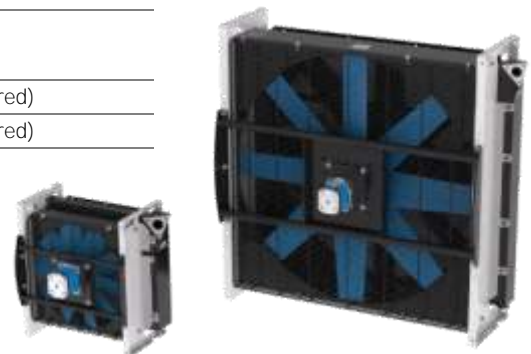

This data sheet and the corresponding scale drawings are to be used as a general guideline and technical overview of our products. Please contact us if more exact information is needed. As we are constantly improving our products, their characteristics, dimensions and weights may also change, although we do our best to incorporate these changes continually. asa assumes no liability for any information therein, any errors, omissions, misprints, nor any direct or indirect damages, losses or costs resulting therefrom. Any cooling performances and general technical values indicated in this catalogue are measured at a test bench according to a test procedure or calculated, based on such tests. Due to different conditions in testing and application environments the performance may also vary by +/- 15%. Because there is no standardized testing procedure, tests used by other manufacturers could have different results. Therefore we recommend all products to be checked under the system operating conditions. This is also true for vibrations and mechanical stress as well as for pressure peaks and thermal stress and any other relevant factors. General tolerances according to DIN ISO 2768-vL. General tolerances for casted parts according EN ISO 8062-3 (DCTG 10). Tolerances for rubber parts are according to ISO 3302-1 (class M4-F+). The tolerances of welding seams are defined by quality group D according to EN ISO 10042, if it is not specified on the actual scale drawing or data sheet. In addition to that we point out that any data sheet and corresponding scale drawing is no substitution for the manual.

# Accessories

## Connector ASA Series

### Description

The asa universal connector is a patented system that offers many possibilities regarding dimension and direction of the hydraulic connection.

With each connector you can choose from 3 directions how to install it into the hydraulic circuit. The stream optimized design reduces the total pressure drop on the cooler. The omission of screwed joints reduces the number of sealing surfaces. The available connector dimensions depend on the cooler size and are shown in the table below.

Our newest option is an intermediate plate for having an additional BSP 1/2" port, which can also be turned in any required direction.



### Dimensions

#### AUC NG 32 – 40 Connectors

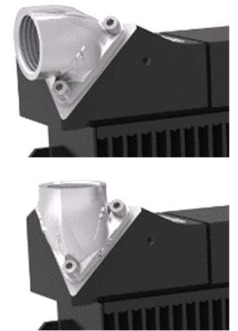
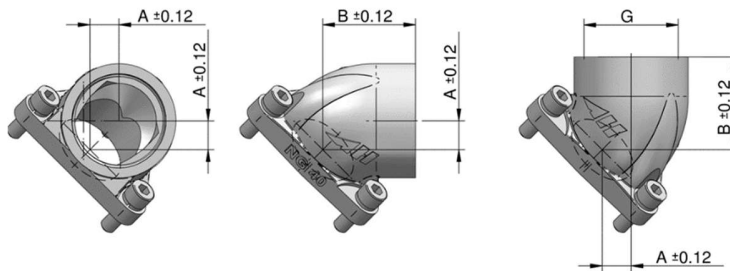

#### Intermediate plate NG 40

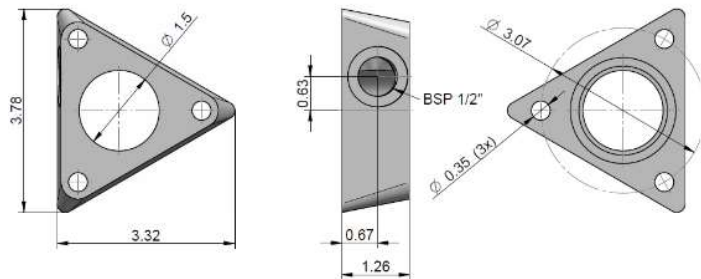

### Technical Data

order number	description	A	B	G	connector material	o-ring	weight
		[in]	[in]				[lbs]
ILLZASA32U20U00	AUC NG 32 – UN 1 <sup>5</sup> / <sub>8</sub> "	0.55	1.34	UN 1 <sup>5</sup> / <sub>8</sub> "	aluminum	NBR 70 shore, 1.73x0.12in	0.68
ILLZASA40U24U00	AUC NG 40 – UN 1 <sup>7</sup> / <sub>8</sub> "	0.59	1.85	UN 1 <sup>7</sup> / <sub>8</sub> "			0.64
ILLZASA32G32U00	AUC NG 32 – G 1 1/4"	0.59	1.34	BSP 1			0.70
ILLZASA40G40U00	AUC NG 40 – G 1 1/2"	0.59	1.85	BSP 1			0.60
ILLZASA40-40G12U00	intermediate plate NG 40	-	-	-			0.66

### Content (except intermediate plate)

asa universal connector	2x
o-ring	2x
screw	6x

### Fits On Cooler Types

ILLZASA32U20U00	ASA 0177, 0257, 0367, 0467, 0567, 0727, 0927
ILLZASA40U24U00	ASA 0177, 0257, 0367, 0467, 0567, 0727, 0927

requires 2pcs per cooler



packed size: 2 pieces

This data sheet and the corresponding scale drawings are to be used as a general guideline and technical overview of our products. Please contact us if more exact information is needed. As we are constantly improving our products, their characteristics, dimensions and weights may also change, although we do our best to incorporate these changes continually. asa assumes no liability for any information therein, any errors, omissions, misprints, nor any direct or indirect damages, losses or costs resulting therefrom. Any cooling performances and general technical values indicated in this catalogue are measured at a test bench according to asa testing procedures or calculated, based on such tests. They represent a basis for your product selection. Due to different conditions in testing and application environments the performance may also vary by +/- 15%. All sound values are determined in accordance with ISO 9614-2, DIN EN ISO 11203 accuracy class 3 or Machinery Directive 2006/42/EG and are A-rated. At some of the performance data, possible differences to competition data are possible. The reason to that are no existing standardized testing procedures on individual subjects, e.g. for cooling performance measurements. Therefore, we recommend all products to be checked under the system operating conditions. This is also true of vibrations and mechanical stress as well as for pressure peaks and thermal stress and any other relevant factors. General tolerances according to DIN ISO 2768-vL, General tolerances for casted parts according to EN ISO 8062-3 (DCTG 10). Tolerances for rubber parts are according to ISO 3302-1 (class M4-F+C). The tolerances of welding seams are defined by quality group D according to EN ISO 10042, if it is not specified on the actual scale drawing or data sheet. Any form of liability is excluded for the information included in this datasheet. All details and calculation values are checked to the best of our ability, but these do not ensure any intrinsic product properties; due to the wide-ranging possible applications, it is advised that all technical data herewith included be confirmed through testing carried out by the end-user. asa technology Produktions- und Vertriebs GmbH reserves the right to modify the product without any separate notification. This refers to both technical data and the product itself. Furthermore, it is herewith specified that the datasheet does not substitute the corresponding scale drawings, assembly and installation guidelines, nor the operating instructions.